

RWF

BRON

OPERATOR'S MANUAL

BRON HSI PLOW

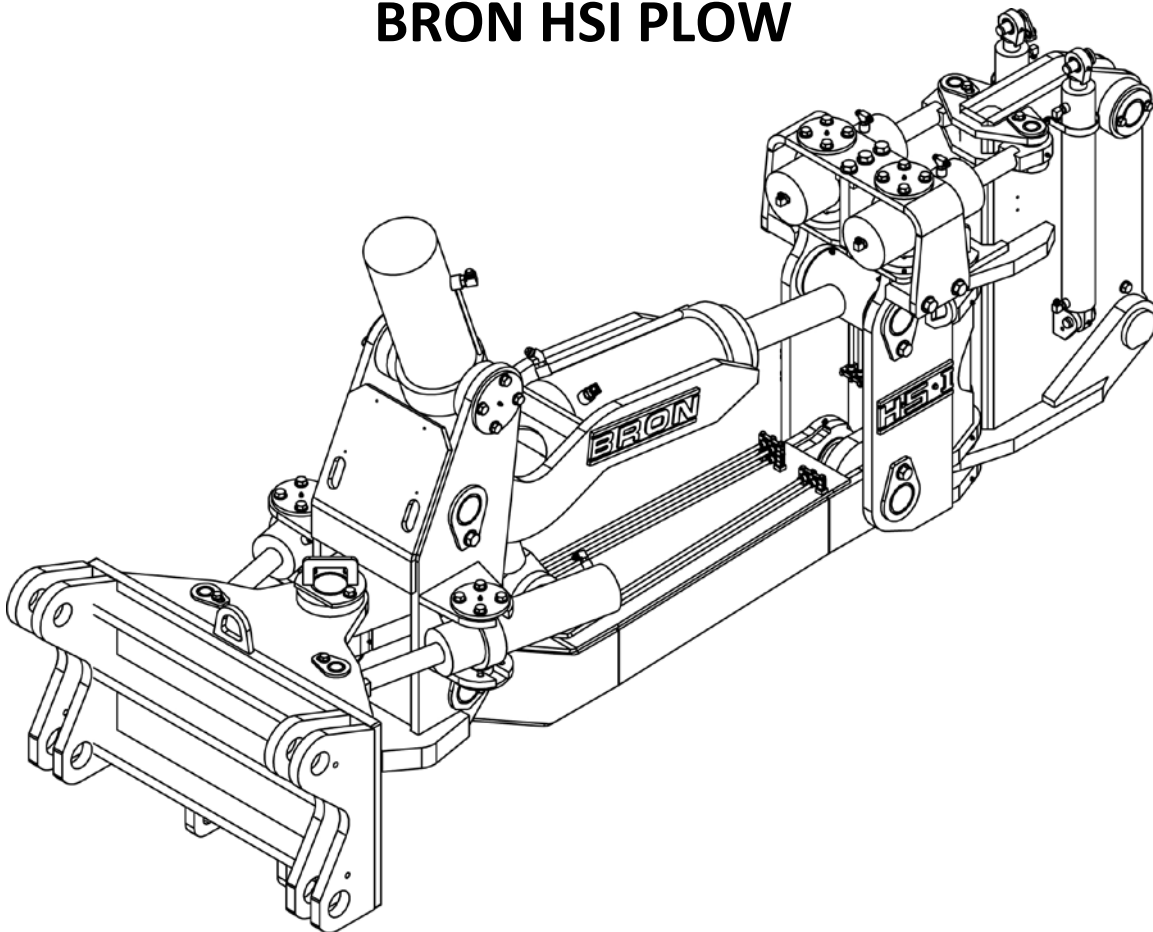

RWF INDUSTRIES

873 Devonshire Ave., Woodstock,

Ontario N4S 8Z4

Tel: (519) 421-0036

Toll Free: 1-800-263-1060

Fax: (519) 421-0028

Email: parts@rwfbron.com

TABLE OF CONTENTS

WARRANTY..... 1

WARNINGS 2.1-15

INSTALLATION 2.2-9

PLOW ASSEMBLY TO TRACTOR..... 2.2

DIRECTIONAL CONTROL VALVE..... 2.3

HALF INCH DIRECTIONAL CONTROL VALVE / FLOW DIVIDER / HYDRAULIC ADJUSTABLE SHANK..... 2.4

HYDRAULIC CAPSTAN LAYDOWN / SHANK & CHUTE 2.5

REEL CARRIER..... 2.6-7

CAPSTAN..... 2.8-9

POWER REWIND..... 2.9

GUIDE FOR HYDRAULIC HOSE SPECIFICATION2.10

FLOW CAPACITIES OF HOSES AT SUGGESTED FLOW VELOCITIES2.10-11

PRE-OPERATION CHECKLIST2.12

LUBRICATION POINTS2.13

OPERATION.....2.14-15



BRON HSI STATIC WARRANTY

BASE WARRANTY (12 months or 2000 hours):

RWF Industries a Division of Roberts Welding & Fabricating Ltd. (RWF) warrants that the new BRON PLOW sold by RWF will be free from defects in material or workmanship for a period of 12 months or 2000 operating hours, whichever occurs first, starting from the date of delivery to the first user.

THIS WARRANTY DOES NOT APPLY TO:

HYDRAULIC and MOUNTING INSTALLATION KIT PARTS, HOSES, OR REPLACEMENT PARTS, which are covered by other warranties

RWF RESPONSIBILITY:

RWF will, at its option, repair or replace with a new or reconditioned part, any warranted part that fails by reason of defective material or workmanship, free of charge delivered at a place of business of an RWF Dealer. Note: parts replaced under warranty become the property of RWF. During the 12 month or 2000 hour BASE WARRANTY period, RWF will pay the reasonable cost of labor that is necessary to install any repaired or replacement part during normal working hours. Overtime rates and travel expenses will not be reimbursed.

USER RESPONSIBILITY:

- The installer, operator, or service person, assumes responsibility to read, understand and comply with RWF's written INSTALLATION, OPERATOR, SERVICE AND WELDING INSTRUCTIONS
- All costs associated with transporting the attachment and/or equipment to an authorized location.
- RWF is not responsible for any expense incurred in field repair.
- Supplying a hydraulic oil sample from the carrier machine based on the following schedule:
 - 1st SAMPLE at the 100 HOUR SERVICE (break-in period)
 - 2nd SAMPLE at the 3 MONTH period (±4 weeks)
 - 3rd SAMPLE at the 6 MONTH period (±4 weeks)
 - 4th (last) SAMPLE at the 9 MONTH period (±4 weeks)

THESE WARRANTIES DO NOT COVER FAILURES RESULTING FROM:

- Installation, alteration, operation, maintenance, repair or storage which RWF judges improper.
- Not performing DAILY VISUAL INSPECTIONS AND RETIGHTENING as specified in RWF Manuals.
- Not following RWF's recommended welding procedure.
- Operation after discovery of defective or worn parts.
- Unreasonable delay in making a repair after being notified of a potential problem.
- Acts of God, war, vandalism, riot, theft, explosion, and any other act of nature or man

THESE WARRANTIES SPECIFICALLY EXCLUDE:

- Installations not approved by RWF.
- Hardface welding to build up wear on surfaces.
- Replacement due to wear.
- Ground engaging tools. Points, guards, blades etc
- Repairs by other than an authorized RWF Dealer.

- Any alteration to BRON products.
- Use of parts not sold by RWF.
- Labor charges deemed excessive by RWF.
- Parts shipping charges in excess of those, which are usual and customary.
- Duty and local taxes.

LIMITATIONS AND EXCLUSIONS:

Violation of any federal, provincial, state or local laws, ordinances, rules or regulations, or removal or alteration of product serial numbers void RWF's written product warranties. The written product warranties made by RWF set forth RWF's only obligations with respect to any claims of failure, defects or deficiencies in products sold by RWF. RWF MAKES NO OTHER WARRANTIES OR REPRESENTATIONS WHATSOEVER, EXPRESS OR IMPLIED, OF THE QUALITY, PERFORMANCE, DURABILITY, MATERIALS, WORKMANSHIP, SUITABILITY, CONDITION, DESIGN OR UTILITY OF PRODUCTS SOLD BY RWF, INCLUDING, WITHOUT LIMITATION, IMPLIED WARRANTIES OR MERCHANT ABILITY AND FITNESS. ALL SUCH OTHER WARRANTIES AND REPRESENTATIONS BEING HEREBY EXPRESSLY EXCLUDED. RWF SHALL NOT BE LIABLE FOR SPECIAL INCIDENTAL OR CONSEQUENTIAL DAMAGES INCLUDING WITHOUT LIMITATION, COSTS, LOSSES, OR LIABILITIES ON ACCOUNT OF DELAY OR DOWNTIME.

DISCLAIMER REGARDING OTHER REPRESENTATIONS OR WARRANTIES:

No person is authorized to grant any other warranties or to assume any other liability on RWF's behalf unless made or assumed in writing by an officer of RWF. No person to grant any warranties or to assume any liabilities on the seller's behalf unless made or assumed in writing by the seller. As used in this warranty the term RWF means, RWF Industries, a division of Roberts Welding and Fabricating Ltd, Woodstock, Ontario, Canada.

SOME ITEMS NOT COVERED BY WARRANTY:

Items and service related functions that are not covered by warranty include, but are not limited to:

- Issues resulting from misuse, negligence or accident.
- Issues arising from the use of non-approved parts.
- Repair or adjustment by other than RWF or its authorized dealers.
- Issues resulting from the installation of unauthorized attachments or modifications.
- Tightening of nuts, bolts, screws, etc. or adjustments.
- Natural wear or defects caused by natural wear.
- Issues due to use of improper grease or other lubricant.
- Daily allowances and overtime labor rates.
- Indirect damages such as loss of earning, etc.
- Normal maintenance services. Maintenance services not directly involved with defective parts are considered normal service and should be excluded from a claim.
- These services include (but not limited to):
- Tightening of hydraulic fittings.
- Hydraulic pressure adjustments.



BRON HSI VIBRATORY WARRANTY

BASE WARRANTY (6 months or 600 hours):

RWF Industries a Division of Roberts Welding & Fabricating Ltd. (RWF) warrants that the new BRON PLOW sold by RWF will be free from defects in material or workmanship for a period of 6 months or 600 operating hours, whichever occurs first, starting from the date of delivery to the first user.

THIS WARRANTY DOES NOT APPLY TO:

HYDRAULIC and MOUNTING INSTALLATION KIT PARTS, HOSES, OR REPLACEMENT PARTS, which are covered by other warranties

RWF RESPONSIBILITY:

RWF will, at its option, repair or replace with a new or reconditioned part, any warranted part that fails by reason of defective material or workmanship, free of charge delivered at a place of business of an RWF Dealer. Note: parts replaced under warranty become the property of RWF. During the 6 month or 600 hour BASE WARRANTY period, RWF will pay the reasonable cost of labor that is necessary to install any repaired or replacement part during normal working hours. Overtime rates and travel expenses will not be reimbursed.

USER RESPONSIBILITY:

- The installer, operator, or service person, assumes responsibility to read, understand and comply with RWF's written INSTALLATION, OPERATOR, SERVICE AND WELDING INSTRUCTIONS
- All costs associated with transporting the attachment and/or equipment to an authorized location.
- RWF is not responsible for any expense incurred in field repair.
- Supplying a hydraulic oil sample from the carrier machine based on the following schedule:
 - 1st SAMPLE at the 100 HOUR SERVICE (break-in period)
 - 2nd SAMPLE at the 3 MONTH period (±4 weeks)
 - 3rd SAMPLE at the 6 MONTH period

THESE WARRANTIES DO NOT COVER FAILURES RESULTING FROM:

- Installation, alteration, operation, maintenance, repair or storage which RWF judges improper.
- Not performing DAILY VISUAL INSPECTIONS AND RETIGHTENING as specified in RWF Manuals.
- Not following RWF's recommended welding procedure.
- Operation after discovery of defective or worn parts.
- Unreasonable delay in making a repair after being notified of a potential problem.
- Acts of God, war, vandalism, riot, theft, explosion, and any other act of nature or man

THESE WARRANTIES SPECIFICALLY EXCLUDE:

- Installations not approved by RWF.
- Hardface welding to build up wear on surfaces.
- Replacement due to wear.
- Ground engaging tools. Points, guards, blades etc
- Repairs by other than an authorized RWF Dealer.
- Any alteration to BRON products.

- Use of parts not sold by RWF.
- Labor charges deemed excessive by RWF.
- Parts shipping charges in excess of those, which are usual and customary.
- Duty and local taxes.

LIMITATIONS AND EXCLUSIONS:

Violation of any federal, provincial, state or local laws, ordinances, rules or regulations, or removal or alteration of product serial numbers void RWF's written product warranties. The written product warranties made by RWF set forth RWF's only obligations with respect to any claims of failure, defects or deficiencies in products sold by RWF. RWF MAKES NO OTHER WARRANTIES OR REPRESENTATIONS WHATSOEVER, EXPRESS OR IMPLIED, OF THE QUALITY, PERFORMANCE, DURABILITY, MATERIALS, WORKMANSHIP, SUITABILITY, CONDITION, DESIGN OR UTILITY OF PRODUCTS SOLD BY RWF, INCLUDING, WITHOUT LIMITATION, IMPLIED WARRANTIES OR MERCHANT ABILITY AND FITNESS. ALL SUCH OTHER WARRANTIES AND REPRESENTATIONS BEING HEREBY EXPRESSLY EXCLUDED. RWF SHALL NOT BE LIABLE FOR SPECIAL INCIDENTAL OR CONSEQUENTIAL DAMAGES INCLUDING WITHOUT LIMITATION, COSTS, LOSSES, OR LIABILITIES ON ACCOUNT OF DELAY OR DOWNTIME.

DISCLAIMER REGARDING OTHER REPRESENTATIONS OR WARRANTIES:

No person is authorized to grant any other warranties or to assume any other liability on RWF's behalf unless made or assumed in writing by an officer of RWF. No person to grant any warranties or to assume any liabilities on the seller's behalf unless made or assumed in writing by the seller. As used in this warranty the term RWF means, RWF Industries, a division of Roberts Welding and Fabricating Ltd, Woodstock, Ontario, Canada.

SOME ITEMS NOT COVERED BY WARRANTY:

Items and service related functions that are not covered by warranty include, but are not limited to:

- Issues resulting from misuse, negligence or accident.
- Issues arising from the use of non-approved parts.
- Repair or adjustment by other than RWF or its authorized dealers.
- Issues resulting from the installation of unauthorized attachments or modifications.
- Tightening of nuts, bolts, screws, etc. or adjustments.
- Natural wear or defects caused by natural wear.
- Issues due to use of improper grease or other lubricant.
- Daily allowances and overtime labor rates.
- Indirect damages such as loss of earning, etc.
- Normal maintenance services. Maintenance services not directly involved with defective parts are considered normal service and should be excluded from a claim.
- These services include (but not limited to):
- Tightening of hydraulic fittings.
- Hydraulic pressure adjustments.

INTRODUCTION

WARNINGS

This manual contains installation instructions, pre-operation checklist, operating procedures, parts and components for the BRON Static Plows.

Some items and procedures listed in this manual are for optional accessories that may not apply to the particular plow package purchased or the tractor it is mounted on.

WARNING



Do not weld on the shank or linkages. They are made from heat-treated alloy steel.

**Applying drawbar pull of more than:
75,000 LBS to the HSI plow will void warranty**

All hydraulic lines, valve, etc., installed within the tractor's cab should have guards installed to protect the operator in case of any hydraulic oil ruptures.

Hydraulic system referred to in this manual is for a fixed volume (gear of vane pump) with open centre spooling.

Consult RWF Industries a Division of Roberts Welding & Fabrication (RWF) for variable volume (pressure compensating) system with closed centre spooling.

INSTALLATION

Plow Assembly to Tractor

1. Remove all attachments and studs/bolts from the rear of the transmission case.
2. Remove all paint (on the tractor) from the area to be covered by the plow's backplate. Grind off all burrs and rough spots.
3. Clean out tapped stud/bolt holes to remove any dirt or rust. If possible, run a tap into the holes to remove any burrs, or foreign material in the bottom of the threads.
4. Attach the plow's backplate to the housing using the correct length and diameter of studs/bolts. Studs should be threaded into the full depth available in the housing.
5. Hi-torque washers and grade 8 nuts or equivalent should be used where required.
6. Apply Loctite to studs, bolts and hole threads.
7. Torque all studs, bolts and nuts according to the original tractor manufacturer's specifications. The following torque chart maybe used as an approximate guideline.

Torque Chart

DIAMETER	N C	N F
¾	275	225
⅞	375	300
1	550	450
1¼	750	600
1½	900	675

NOTE

Some tractor installations may have a pinned connection between the tractor and the plow's backplate. For this attachment, the backplate will be designed accordingly. Dealer supplied pins will be required in lieu of mounting bolts and/or studs.

Directional Control Valve

A separate section of the control valve is required for each operation of the plow assembly:

- Front swing
- Rear swing
- Main lift
- Shank attitude
- Adjustable shank (if included in plow assembly)
- Hydraulic capstan laydown (if included in plow assembly)

The control valve is normally mounted on the right hand side of the operator, thereby permitting a rear view of the plow's shank and chute and a forward view of the tractors direction.

The hydraulic hoses for connection between the tractor, control valve and hydraulic manifold that is mounted on the main mast of the plow are to be supplied by the installing dealer. Hydraulic hose sizes from the directional control valve to the plow's manifold should be of the same diameter as the respective fittings at the manifold. Refer to Hydraulic hose specification for hose diameter sizing and specifications.

If a flow divider is required in the hydraulic system (i.e. for capstan and/or power rewind), the pressure line from the tractor's pump is connected to the pressure-in (pump port) of the control valve.

NOTE

On some tractors, a separate pump maybe installed. In this case, the power beyond and tank are connected together and the return line runs directly back to the tank.

The return line should be connected near the bottom side of the tank and deflected away from the suction line.

An alternative is to go into the top of the tank with a stand pump down to the bottom of the tank and deflected away from the suction line.

Refer to the hydraulic schematic for location and attachment of the directional control valve.

Half Inch Directional Control Valve (Capstan and/or Power Rewind)

If a capstan and/or power rewind is part of the plow assembly, than a directional control valve is required. A single section valve is required to operate either the capstan or the power rewind. If both the capstan and power rewind is part of the same plow assembly, than a dual section control valve is required.

This valve functions as an on/off in addition to controlling the direction (forward/reverse) of the capstan sheave and/or the power rewind wheel.

This control valve should be mounted in a convenient location to the right hand side of the operator.

Dealer supplied hydraulic lines are required to connect to and from this valve. The hydraulic hose should be ½" diameter 100R2 specification or equivalent (rated for 3000 PSI working pressure).

Refer to the hydraulic schematic for the location and attachment of the ½" directional control valve.

Flow Divider (Capstan and/or Power Rewind)

If a capstan and/or power rewind is part of the plow assembly, than a flow divider is required.

This valve diverts 10 gallons per minute of controlled flow to the directional valve. It should be mounted between the tractor pump and the main directional control valve; the size of flow divider required is determined by the GPM of the tractor pump and should have been specified at time of order.

Dealer supplied hydraulic lines are required to connect to and from this valve. Refer to Hydraulic hose specification for hose diameter sizing and specifications.

Refer to the hydraulic schematic for the location and attachment of the control valve.

Hydraulic Adjustable Shank

For plow assemblies equipped with this option, an additional section is required in the directional control valve. This section must be connected to the appropriate lines on the hydraulic manifold that is mounted on the main mast of the plow assembly.

This additional section controls the shank height from the minimum to the maximum depth permissible depending on plow model and shank dimension. The shank is held in position with a double lock valve when the directional valve section is in neutral.

Dealer supplied hydraulic lines are required to connect from the directional control valve section to the plow manifold.

Hydraulic Capstan Laydown

For plow assemblies equipped with this option, an additional section is required in the directional control valve. This section must be connected to the appropriate lines on the hydraulic manifold that is mounted on the main mast of the plow assembly.

Dealer supplied hydraulic lines are required to connect from the directional control valve section to the plow manifold.

Shank & Chute

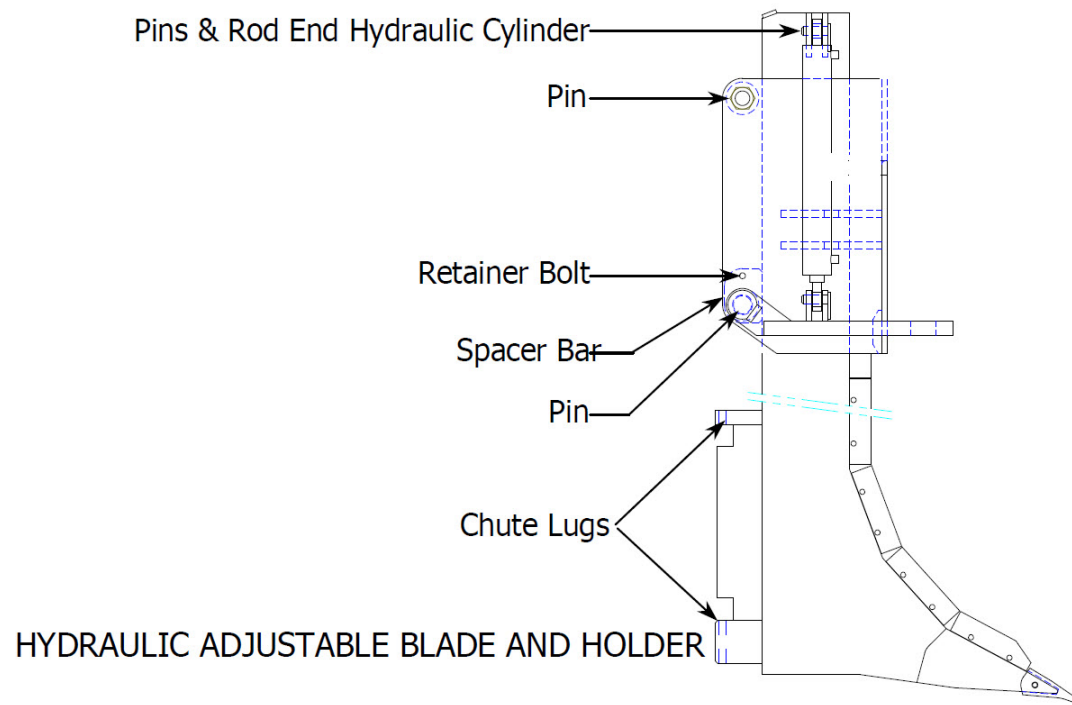

Shank

1. Remove the rear pins and spacer bar (if hydraulically adjustable shank) from the blade holder.
2. Slide shank into rear of blade holder.
3. Install pins and spacer bar (if hydraulically adjustable shank).
4. For hydraulically adjustable shank, hook up rod end of adjustable cylinder to brackets at top of shank and install pin and keeper bolt.

Chute

Pin lugs on front of chute to lugs on back of shank.

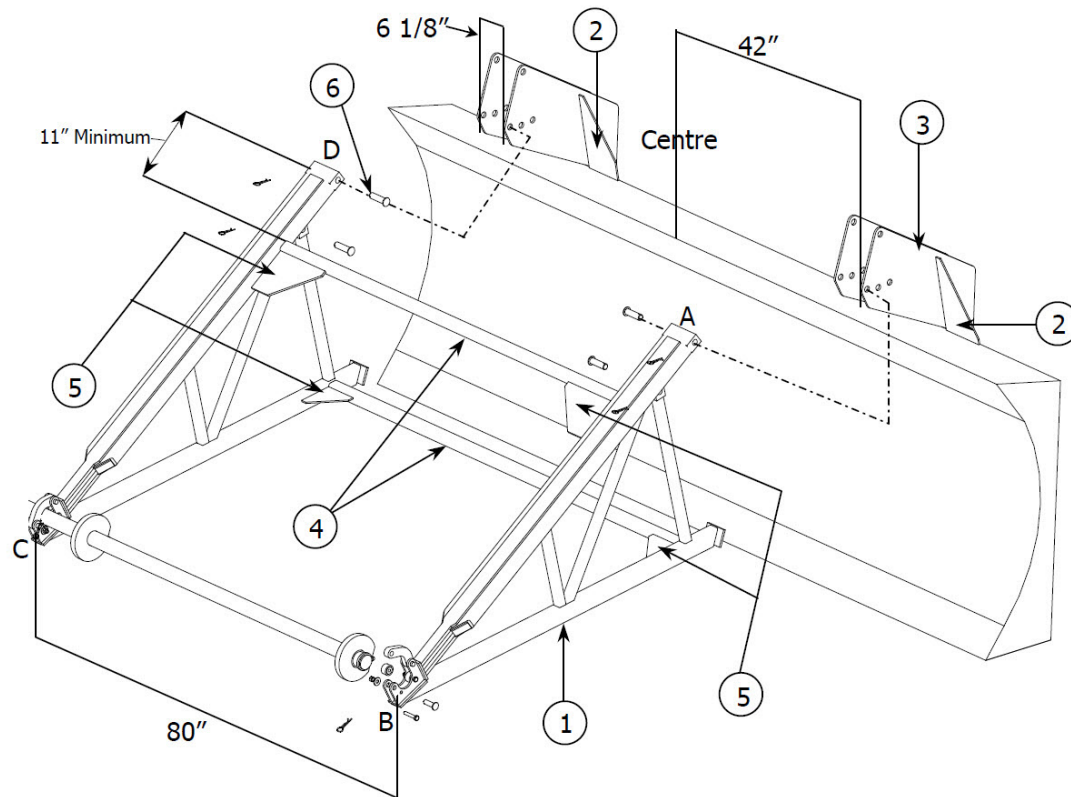
Reel Carrier**Blade Mount**

1. From centre of blade length, measure 42" in each direction and mark same on top leading edge of blade.
2. Place inner edge of outside mounting plates (3) at the 42" marks and tack weld.
3. Place inside mounting plates 6 1/8" from the respective outside mounting plates and tack weld.

NOTE

Ensure that the four mounting plates are in line with each other prior to tack welding.

4. Tack weld gusset plates (2).
5. Attach side frames (1) to mounting plates with pins (6). Side frames should be 80" apart, outside edge to outside edge.
6. Attach arbour onto ends of side frame.
7. Check that the side frames are square by measuring diagonally from points A to D and from C to B. (see drawing above)
8. Ensure that the centre line of the arbour is approximately 12" from ground level while the blade is sitting on the ground.
9. After ensuring that the side frames are square, tack weld the cross tubes (4) as per diagram.
10. Install corner gussets (5) as indicated on the diagram and tack weld into position.
11. Do final check that everything is square and correct. Weld all areas that have previously been tack welded.

Frame Mount

1. Clean hard nose area of tractor prior to mounting reel carrier.
2. Attach mounting brackets as per drawing supplied with reel carrier. Bracket locations will vary depending on make and model of tractor.
3. Tack weld brackets.
4. Mount reel carrier to brackets and check for proper alignment and clearances.
5. Complete welding all areas previously tack welded using ½" fillet welds.
6. Check all hardware fasteners for tightness.

Capstan

Fixed (Pinned) Shank

1. Remove the hinge pin (4) from the existing plow mount (1" diameter shaft).
2. Set capstan assembly on existing mount and line up hinge assembly.
3. Reinstall the hinge pin and attach the R clips to retain shaft assembly.
4. Ensure that ½" bolts line up with existing plates.
5. Lay capstan down into transport position to ensure that the stop bracket allows for a ½" clearance between the blade holder and capstan motor.

Hydraulically Adjustable Shank

1. Attach mounting block supplied to the top of the shank and completely weld.
2. Install bottom hinge section.
3. Check all hardware fasteners for tightness.
4. Set capstan assembly on existing mount and line up hinge assembly.
5. Re install the hinge pin and attach the R clips to retain shaft assembly.
6. Insure that half inch bolts line up with existing plates.
7. Lay capstan down into transport position to insure that the stop bracket allows for ½" clearance between blade holder and capstan motor.

Hydraulic Laydown Option

1. Install hinged base plate as per drawing supplied.
2. Set capstan assembly on hinged base plate, insert shaft and attach R clips to retain shaft into hinges.
3. Pin laydown cylinder to upper clevis.

CAUTION



When attempting to operate for the first time, be sure to bleed hydraulic lines, so capstan will not fall over suddenly.

Power Rewind

1. Bolt mounting brackets (3 & 4). Inside dimension between brackets will be determined by slide bar shaft (6).
2. Check alignment by installing the two side bar shafts (6).
3. If alignment is correct, tighten the mounting bracket bolts.
4. Remove the two shafts (6) and insert the arm weldment (1). Reinstall the two shafts and attach the R clips.
5. Install adjustment screw assembly as per diagram.
6. To obtain desired height position of wheel, use adjustment pin assembly (8).

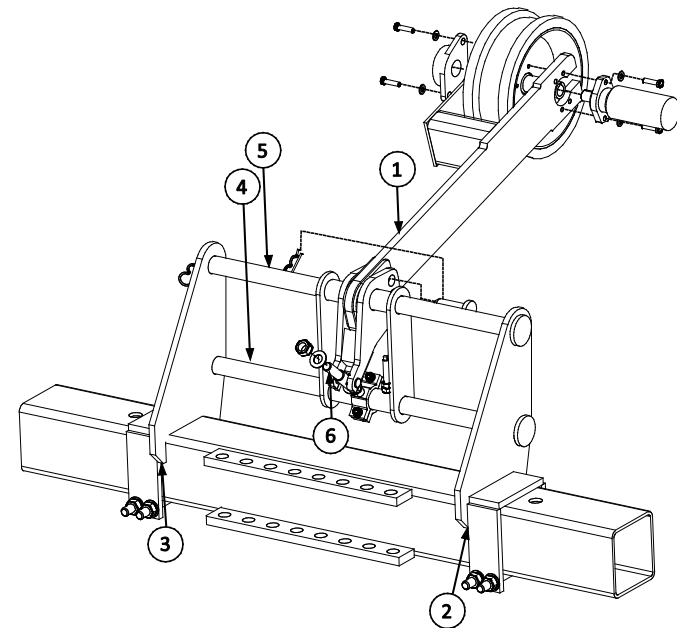

GUIDE FOR HYDRAULIC HOSE SPECIFICATION

Hose Size	Specification	Usage
3/8, 1/2	SAE 100R2 or SAE100R2A	Recommended for pressure lines up to 2500 PSI
3/4	SAE100R2A or equivalent	
1, 1 1/4	SAE100R9A four light spiral wire or equivalent	
1, 1 1/4, 1 1/2, 2	SAE100R4	Recommended for suction lines (may also be used for low pressure return lines 100 PSI)

FLOW CAPACITIES OF HOSE ASSEMBLIES AT SUGGESTED FLOW VELOCITIES

The chart on the next page is designed and provided as an aid in the determination to the correct hose size.

Example:

At 13 gallons per minute, what is the proper hose size within the suggested velocity range for pressure lines?

Solution:

Locate 13 gallons per minute in the left hand column and 10 feet per second in the right hand column (the centre of the suggested velocity range for pressure lines). Lay a straight edge across these two points. The inside diameter required to give the desired velocity is the actual inside diameter shown in the centre column nearest the straight edge

For suction hoses, follow the same procedure except use suggested velocity range for intake.

Based on the Formula:

$$\text{Area (SQ. IN.)} = \frac{\text{G.P.M X 0.3208}}{\text{Velocity (FT/SEC)}}$$

* Suggestions are for oils having a maximum viscosity of 315 SSU at +100°F (+38°C) and operating at temperature between +65°F (+54°C) and +155°F (+69°C). Under certain conditions velocities in pressure lines can be increased up to 25 feet per second.

FLOW U.S. GALLONS PER MINUTE

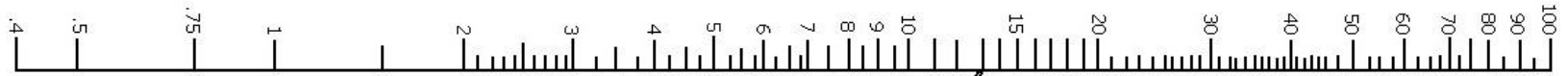

INSIDE DIAMETER OF HOSE, IN

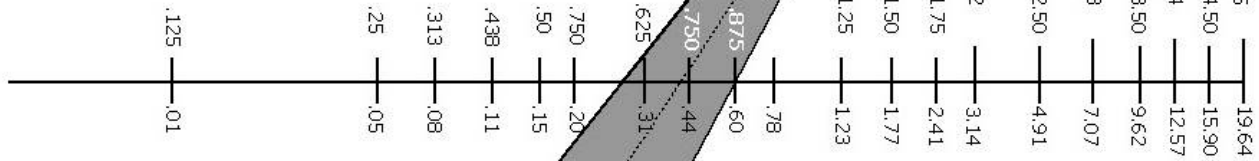

AREA IN SQ. IN.

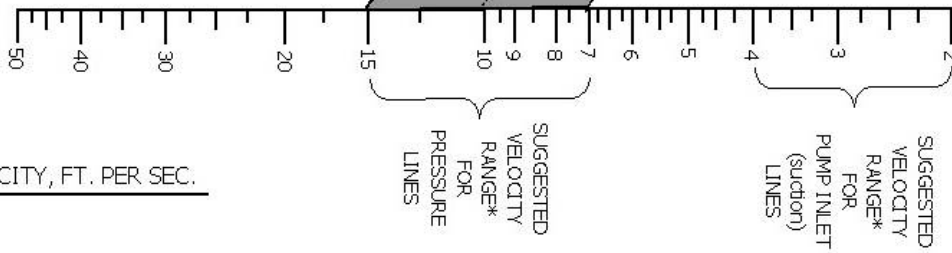

VELOCITY, FT. PER SEC.

PRE-OPERATION CHECK LIST

7. Prior to any movement of the plow functions, lubricate all points as per lubrication guide on the following pages.
8. Ensure that all hydraulic lines, valves, etc., that may have been installed within the tractor's cab are properly guarded to protect the operator in case of hydraulic oil ruptures.
9. Check the hydraulic oil system to ensure that it is filled to the tractor manufacturers specifications.
10. Start up the tractor and engage each control of the plow and related accessories to ensure that proper connections have been made and that there are no interference fits.
11. Check all hydraulic connections for leaks.
12. Check all fasteners to ensure that they are properly torqued.
13. To protect hydraulic circuit and pump, line pressure must not exceed 3200 PSI.
 - a) Install pressure gauge in pressure line between tractor pump and directional control valve.
 - b) Activate main lift cylinder to raise plow to maximum position. Hold control lever open to build up line pressure.
 - c) Adjust relief setting in manifold inlet section of directional control valve to obtain 3200 PSI reading on the pressure gauge.
14. Ensure that the hydraulic lines to the hydraulic capstan laydown are bled of air before attempting to operate.

LUBRICATION POINTS

Reference lubrication drawing on the following page.

Lubricate daily with good quality multi-purpose grease.

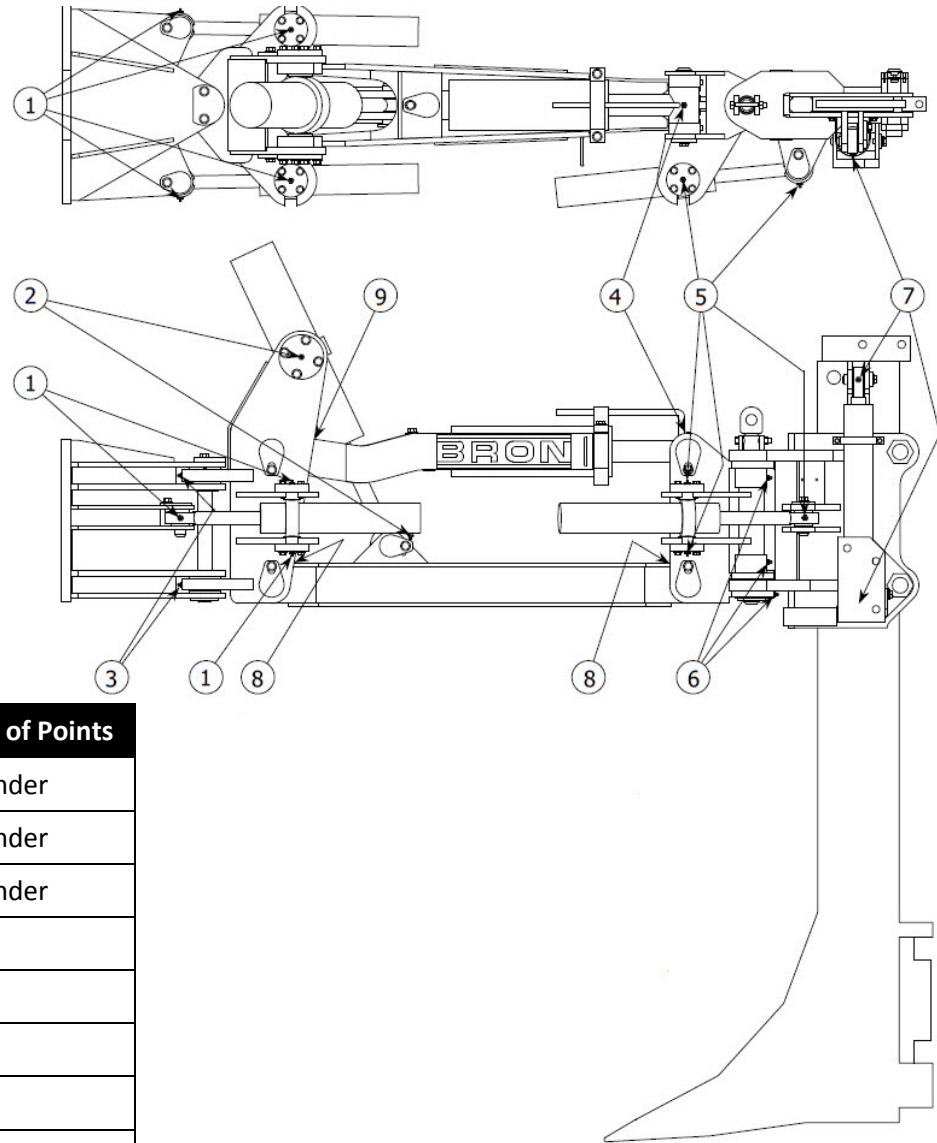

Location	Description	Number of Points
1	Front swing	3 per cylinder
2	Rear swing	3 per cylinder
3	Lift cylinder	3 per cylinder
4	Main mast	2
5	Upper link	4
6	Lower link	4
7	Rear link	3
8	Hydraulically adjustable shank spacer bar	1
9	Hydraulic capstan laydown	5

OPERATION

Main Directional Control Valve

Main Lift

This section controls the lift cylinder(s) and raises/lowers the plow assembly.

Front Swing

This section controls the two front swing cylinders connected to the backplate and main mast of the plow assembly. These cylinders activate the offsetting of the plow, right and left of centre. This section contains a float detent. To place front swing cylinder into float, pull control lever hard towards operator. If directional control valve has been incorrectly mounted, in upside down position, then cylinders should be in float during most plow conditions other than plowing on steep side slopes or when plowing in maximum offset position. Operator preference and experience will determine ultimate use of the float detent.

Rear Swing

This section controls the parallel direction of the shank and chute. The shank and chute should be parallel to the tractor during plowing mode.

Attitude

This section controls the angle of attitude of the shank. By angling the point of the shank towards the tractor, the shank will want to ride out of the ground. If the shank point is angled back away from the tractor, the shank will want to plow deeper into the ground. Once the desired plow depth has been achieved, the shank attitude should only be used to maintain desired depth.

Adjustable Shank Lift

This section raises and lowers the shank. When the directional valve section is in neutral, the shank is held in position with a double lock valve.

Capstan Laydown Assembly

NOTE

Ensure that both locking bolts are always in place prior to using the capstan.

The capstan when upright and in operating mode is held in position by two nuts and bolts. Prior to laying down the capstan for transport, remove these two nuts and bolts. The control section of the directional control valve is used to raise or lower the capstan.

Capstan and/or Power Rewind

The ½" directional valve (single or dual) controls the direction of the capstan sheave and/or power rewind wheel.

The hydraulic motor for the capstan and power rewind wheel requires 10 GPM, from the power source through the speed control, to operate the motor and develop a maximum of 96 wheel revolutions at full engine RPM. The speed control will regulate the sheave/wheel RPM from 0 (off) to maximum. Torque pressure of the sheave/wheel is 450 pounds at a maximum relief setting of 2000 PSI.