

# RWF BRON

## HS-X-1 PLOW OPERATOR'S MANUAL

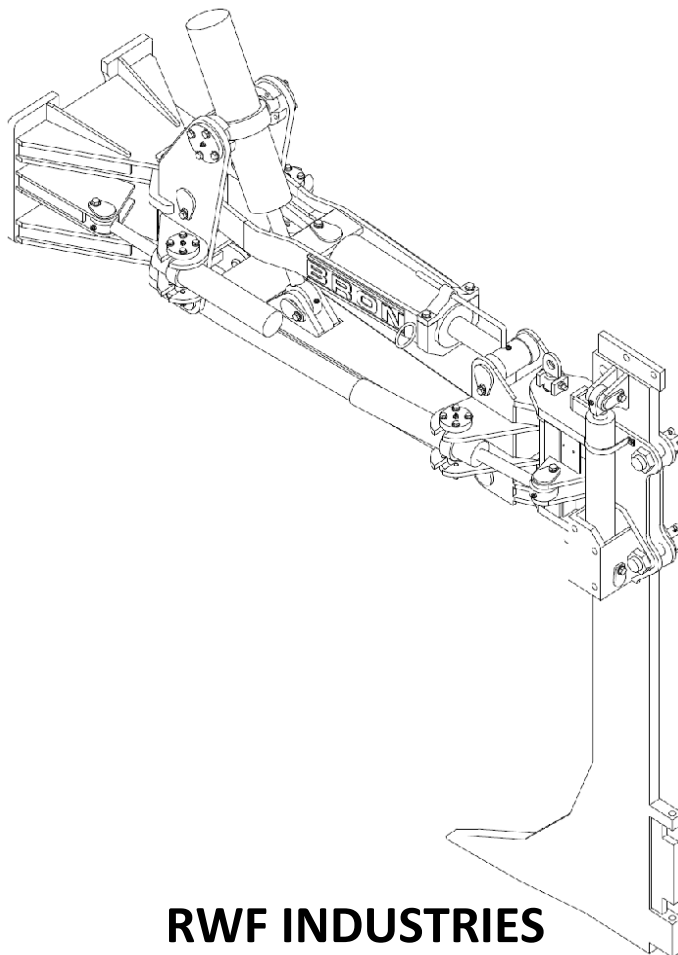

### RWF INDUSTRIES

873 Devonshire Ave., Woodstock,

Ontario N4S 8Z4

Tel: (519) 421-0036

Toll Free: 1-800-263-1060

Fax: (519) 421-0028

Email: [parts@rwfbron.com](mailto:parts@rwfbron.com)

OPERATOR'S MANUAL

JANUARY 2015

THE INFORMATION CONTAINED IN RWF BRON PARTS AND OPERATOR'S MANUALS IS NOT TO BE REPRODUCED OR DISTRIBUTED TO ANY PERSON OTHER THAN THE INTENDED RECIPIENT

**TABLE OF CONTENTS**

***INTRODUCTION..... 1***

***INTRODUCTION / WARNINGS..... 1.1***

***INSTALLATION..... 1.2***

***DIRECTIONAL CONTROL VALVE PLOW ..... 1.3***

***HYDRAULIC HOSE SPECIFICATION GUIDE..... 1.4-5***

***PRE-OPERATION CHECKLIST / LUBRICATION..... 1.6***

***OPERATION..... 1.6-7***

***WARRANTY..... .2***

## **INTRODUCTION**

This manual contains installation instructions, pre-operation checklist, operating procedures, parts and components for the BRON Static Plows. Some items and procedures listed in this manual are for optional accessories that may not apply to the particular plow package purchased or the tractor it is mounted on.

### **WARNINGS**

#### **WARNING**



**DO NOT WELD ON THE SHANK OR LINKAGES! (They are made from heat-treated alloy steel)**

#### **WARNING**



**ALL HYDRAULIC LINES, VALVES, ETC. INSTALLED WITHIN THE TRACTOR CAB SHOULD HAVE GUARDS INSTALLED TO PROTECT THE OPERATOR IN CASE OF ANY HYDRAULIC OIL RUPTURES!**

#### **WARNING**



**APPLYING DRAWBAR PULL OF MORE THAN 40,000 LBS TO THE HS-X-1 PLOW WILL VOID WARRANTY!**

#### **NOTE**

Hydraulic system referred to in this manual is for a fixed volume (gear of vane) pump with open centre spooling. Consult RWF BRON for variable volume (pressure compensating) system with closed centre spooling.

#### **NOTE**

The hydraulic system is designed to operate at 2500PSI.

RWF INDUSTRIES RESERVES THE RIGHT TO MAKE IMPROVEMENTS IN DESIGN, MATERIAL AND/OR CHANGES IN SPECIFICATIONS AT ANY TIME WITHOUT INCURRING ANY OBLIGATION RELATED TO SUCH CHANGES.

## INSTALLATION

### Plow Assembly to Tractor

- A. Remove all attachments and studs / bolts from the rear of the transmission case.
- B. Remove all paint (on the tractor) from the area to be covered by the plow's backplate. Grind off all burrs and rough spots.
- C. Clean out tapped stud / bolt holes to remove any dirt or rust. If possible run a tap into the holes to remove any burrs, or foreign material in the bottom of the threads.
- D. Attach the plow's backplate to the housing using the correct length and diameter studs / bolts. Studs should be threaded into the full depth available in the housing.

#### NOTE

Seal any openings in the transmission that are covered by backplate with silicone seal. This is to prevent water contamination in the transmission.

- E. Hi-torque washers and Grade 8 nuts or equivalent should be used where required.
- F. Apply Loctite to studs, bolts and hole threads.
- G. Torque all studs, bolts and nuts according to the original tractor manufacturer's specifications.

The following torque chart may be used as an approximate guide for non-plated bolts and nuts.

#### NOTE

Some tractor installations may have a pinned connection between the tractor and the plow's backplate.  
For this attachment, the backplate will be designed for same.  
Dealer supplied pins will be required in lieu of mounting bolts and/or studs.

Diameter	DRY - NC	DRY - NF	LUB - NC	LUB - NF
¾"	370	415	200	225
⅞"	600	660	330	360
1"	900	990	495	545
1¼"	1800	1995	990	1095
1½"	3150	3550	1730	1950

## ***DIRECTIONAL CONTROL VALVE FLOW***

A separate section of the control valve is required for each operation of the plow assembly

<b>FRONT SWING</b>	<b>REAR SWING</b>	<b>MAIN LIFT</b>	<b>SHANK ATTITUDE</b>	<b>ADJUSTABLE SHANK (IF INCLUDED)</b>	<b>STABILIZER ARM</b>	<b>ROTATOR CYLINDER</b>
--------------------	-------------------	------------------	-----------------------	---------------------------------------	-----------------------	-------------------------

The hydraulic hoses for connections between the pump, hydraulic tank, control valve and hydraulic manifold (mounted on the backplate of the plow) are to be supplied by the installing dealer. Hydraulic hose sizes from the directional control valve to the plow's manifold should be of the same diameter as the respective fittings at the manifold.

### **NOTE**

A separate pump may be installed for each pump with the power beyond and tank connected and the return line run directly back to the tank.

The return line should be connected near the bottom side of the tank and bent away from the suction line. Alternatively go into the top of the tank with a stand pipe down to the bottom of the tank deflected away from the suction line. See the hydraulic schematic for the directional control valve.

## ***Hydraulic Adjustable Shank***

For plow assemblies equipped with this option, an additional section is required in the directional control valve. This section must be connected to the appropriate lines on the hydraulic manifold that is mounted on the main mast of the plow assembly. This additional section controls the shank height from the minimum to the maximum permissible depth depending on plow model and shank dimension. The shank is held in position with a double lock valve when the directional valve section is in neutral. Dealer supplied hydraulic lines are required to connect from the directional control valve section to the plow manifold.

### **NOTE**

Blade height must be adjusted before blade is engaged into the ground.

### ***Shank***

- Remove the rear pins and spacer bar (if hydraulically adjustable shank) from the blade holder.
- Slide shank into rear of blade holder.
- Install pins and spacer bar (if hydraulically adjustable shank).
- For hydraulically adjustable shank, hook up rod end of adjustable cylinder to brackets at top of shank and install pin and keeper bolt.

### ***Chute***

- Pin lugs on front of chute to lugs on back of shank.

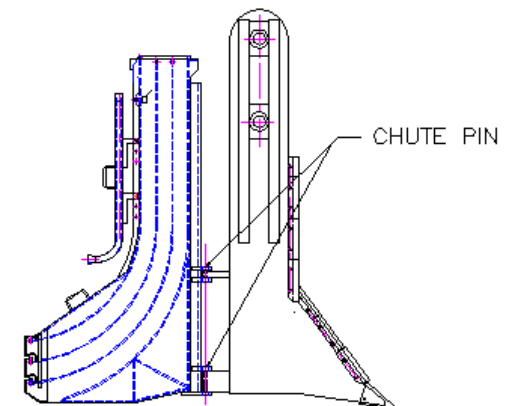

**HYDRAULIC HOSE SPECIFICATION GUIDE**

HOSE SIZE	SPECIFICATIONS	USAGE
3/8, 1/2	SAE 100R2 OR SAE 100R2A	RECOMMENDED FOR PRESSURE LINES UP TO 2500PSI
3/4	SAE 100R2A OR EQUIVALENT	
1	SAE 100R9A 4 WIRE OR EQUIVALENT	
1 1/4	SAE 100R9A 4 WIRE OR EQUIVALENT	RECOMMENDED FOR SUCTION LINES OR LOW PRESSURE RETURN LINES 100PSI MAX
1, 1 1/4, 1 1/2, 2	SAE 100R4	

Flow capacities of hose assemblies at suggested flow velocities in the table above.

The chart on the next page is designed and provided as an aid in the determination of the correct hose size.

**Example:** At 13 Gallons per minute, what is the proper hose size within the suggested velocity range for pressure lines?

**Solution:** Locate 13 gallons per minute in the left hand column and 10 feet per second in the right hand column (the centre of the suggested velocity range for pressure lines). Lay a straight edge across these two points. The inside diameter required to give the desired velocity is the actual inside diameter shown in the centre column nearest the straight edge.

For suction hoses, follow the same procedure except use suggested velocity range for intake.

Based on Formula

$$\text{AREA (SQ. IN.)} = \frac{\text{G.P.M.} \times 0.3208}{\text{Velocity (FT/SEC)}}$$

Velocity (FT/SEC)

\*\* Suggestions are for oils having a maximum viscosity of 315 SSU at +100°F (+38°C) and operating at temperatures between +65° F and +155°F (+54°C to +69°C). Under certain conditions velocities in pressure lines can be increased up to 25 feet per second.

FLOW U.S. GALLONS PER MINUTE



INSIDE DIAMETER OF HOSE, IN

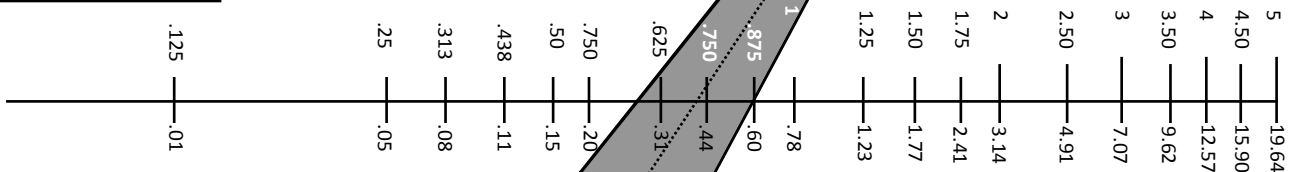

AREA IN SQ. IN.

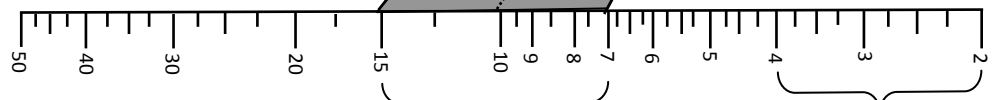

VELOCITY, FT. PER SEC.

SUGGESTED VELOCITY RANGE\* FOR

SUGGESTED VELOCITY RANGE\* FOR

**PRE-OPERATION CHECK LIST**

1. Prior to any movement of the plow functions, lubricate all points as per lubrication guide on the following pages.
2. Ensure that all hydraulic lines, valves, etc. that may have been installed within the tractor cab are properly guarded to protect the operator in case of any hydraulic ruptures.
3. Check the hydraulic oil system to ensure that it is filled to the tractor manufacturer's specifications.
4. Prior to operation of hydraulics, ensure that no air is trapped in the circuit.
5. Start tractor and engage each function control of the plow and related accessories to ensure that the proper connections have been made and that there are no interference fits.
6. Check all hydraulic connections for leaks.
7. Check all fasteners to ensure that they are properly torqued.
8. To protect hydraulic circuit and pump, line pressure must not exceed 2500 PSI.  
To set pressure at 2500 PSI:
  - a) Install pressure gauge in pressure line between tractor pump and directional control valve.
  - b) Activate main lift cylinder to raise plow to maximum position. **Hold** control lever open to build up line pressure.
  - c) Adjust relief setting in manifold inlet section of directional control valve to obtain 2500 PSI reading in the pressure gauge.
9. Ensure that the hydraulic lines to the hydraulic capstan laydown are bled of air before attempting to operate.

**LUBRICATION**

Location	Description	# of Points
1	Front Swing	3 Per Cylinder
2	Rear Swing	
3	Lift Cylinder	
4	Blade Height Cylinder (If Applicable)	4
5	Main Mast	5
6	Upper Link	2
7	Lower Link	4
8	Rear Mast	5
9	Rotator	4
10	Rotator Cylinder	3
11	Blade Holder (If Applicable)	4
Lubricate daily with good quality multi-purpose grease!		

**OPERATION****Rear Swing**

This section controls the two rear swing cylinders connecting the rotator to the blade holder. These cylinders will steer the blade to allow offset of the plow to the tractor, and to maintain the desired offset.

**Attitude**

This section controls the angle or attitude of the shank. If angling the point of the shank toward the tractor, the shank will ride out of the ground. If angling the point of the shank away from the tractor, the shank will plow deeper into the ground. Once the desired plow depth has been achieved, the shank attitude should only be used to maintain desired depth.



**Rotator**

This section controls the rotator cylinder, which facilitates the rotation of the blade perpendicular to the plow linkage.

**Blade Height**

This section raises and lowers the shank. When the directional valve section is in neutral, the shank is held in position with a double lock valve. The blade depth should always be set before the blade is engaged in the ground.

**Main Lift**

This section controls the lift cylinders and raises / lowers the plow assembly. The main lift cylinder contains a float detent which can be activated by pulling the control lever firmly toward the operator. If the directional valve has been mounted upside down, then the float section will work in the opposite direction. The float position may be used when the optional skid plate assembly has been attached to the blade holder. This will allow the plow to ride over the contour of the ground when plowing.

**Front Swing**

This section controls the front swing cylinder connecting the backplate and the main mast of the plow assembly. This cylinder activates the offsetting of the plow to the tractor and contains a float detent. To place front swing cylinder into float, pull the control lever firmly toward the operator. If the directional valve has been mounted upside down, then the float detent position will be in the opposite direction. Once the plow is set at the desired offset, the front swing cylinder should be put into float position. (To maintain offset of the plow, steering is done with the rear swing cylinder).

**Stabilizer Arm**

This section controls the cylinder mounted in the stabilizer arm assembly. The cylinder is used to connect the stabilizer arm to the offset plow at the rotator assembly; the stabilizer arm contains a float section. To place the arm cylinder in float, pull the control lever firmly toward the operator; if the directional valve has been mounted upside down, then the float detent position will be in the opposite direction. Once the stabilizer arm cylinder is connected, the cylinder should be put in float until the desired offset position of the plow is reached; returning the control lever to the neutral position locks in the cylinder.

**NOTE**

The stabilizer arm should always be used when plowing with more than 10' (3m) offset from the outside rail.



## BRON HS-X-1 PLOW WARRANTY

### **BASE WARRANTY (12 months or 2000 hours):**

RWF Industries a Division of Roberts Welding & Fabricating Ltd. (RWF) warrants that the new BRON PLOW sold by RWF will be free from defects in material or workmanship for a period of 12 months or 2000 operating hours, whichever occurs first, starting from the date of delivery to the first user.

### **THIS WARRANTY DOES NOT APPLY TO:**

HYDRAULIC and MOUNTING INSTALLATION KIT PARTS, HOSES, OR REPLACEMENT PARTS, which are covered by other warranties

### **RWF RESPONSIBILITY:**

RWF will, at its option, repair or replace with a new or reconditioned part, any warranted part that fails by reason of defective material or workmanship, free of charge delivered at a place of business of an RWF Dealer. Note: parts replaced under warranty become the property of RWF. During the 12 month or 2000 hour BASE WARRANTY period, RWF will pay the reasonable cost of labor that is necessary to install any repaired or replacement part during normal working hours. Overtime rates and travel expenses will not be reimbursed.

### **USER RESPONSIBILITY:**

- The installer, operator, or service person, assumes responsibility to read, understand and comply with RWF's written INSTALLATION, OPERATOR, SERVICE AND WELDING INSTRUCTIONS
- All costs associated with transporting the attachment and/or equipment to an authorized location.
- RWF is not responsible for any expense incurred in field repair.
- Supplying a hydraulic oil sample from the carrier machine upon request from RWF Bron

### **THESE WARRANTIES DO NOT COVER FAILURES RESULTING FROM:**

- Installation, alteration, operation, maintenance, repair or storage which RWF judges improper.
- Not performing DAILY VISUAL INSPECTIONS AND RETIGHTENING as specified in RWF Manuals.
- Not following RWF's recommended welding procedure.
- Operation after discovery of defective or worn parts.
- Unreasonable delay in making a repair after being notified of a potential problem.
- Acts of God, war, vandalism, riot, theft, explosion, and any other act of nature or man

### **THESE WARRANTIES SPECIFICALLY EXCLUDE:**

- Installations not approved by RWF.
- Hardface welding to build up wear on surfaces.
- Replacement due to wear.
- Ground engaging tools. Points, guards, blades etc
- Repairs by other than an authorized RWF Dealer.
- Any alteration to BRON products.
- Use of parts not sold by RWF.
- Labor charges deemed excessive by RWF.
- Parts shipping charges in excess of those, which are usual and customary.

- Duty and local taxes.

**LIMITATIONS AND EXCLUSIONS:**

Violation of any federal, provincial, state or local laws, ordinances, rules or regulations, or removal or alteration of product serial numbers void RWF's written product warranties. The written product warranties made by RWF set forth RWF's only obligations with respect to any claims of failure, defects or deficiencies in products sold by RWF. RWF MAKES NO OTHER WARRANTIES OR REPRESENTATIONS WHATSOEVER, EXPRESS OR IMPLIED, OF THE QUALITY, PERFORMANCE, DURABILITY, MATERIALS, WORKMANSHIP, SUITABILITY, CONDITION, DESIGN OR UTILITY OF PRODUCTS SOLD BY RWF, INCLUDING, WITHOUT LIMITATION, IMPLIED WARRANTIES OR MERCHANT ABILITY AND FITNESS. ALL SUCH OTHER WARRANTIES AND REPRESENTATIONS BEING HEREBY EXPRESSLY EXCLUDED. RWF SHALL NOT BE LIABLE FOR SPECIAL INCIDENTAL OR CONSEQUENTIAL DAMAGES INCLUDING WITHOUT LIMITATION, COSTS, LOSSES, OR LIABILITIES ON ACCOUNT OF DELAY OR DOWNTIME.

**DISCLAIMER REGARDING OTHER REPRESENTATIONS OR WARRANTIES:**

No person is authorized to grant any other warranties or to assume any other liability on RWF's behalf unless made or assumed in writing by an officer of RWF. No person to grant any warranties or to assume any liabilities on the seller's behalf unless made or assumed in writing by the seller. As used in this warranty the term RWF means, RWF Industries, a division of Roberts Welding and Fabricating Ltd, Woodstock, Ontario, Canada.

**SOME ITEMS NOT COVERED BY WARRANTY:**

Items and service related functions that are not covered by warranty include, but are not limited to:

- Issues resulting from misuse, negligence or accident.
- Issues arising from the use of non-approved parts.
- Repair or adjustment by other than RWF or its authorized dealers.
- Issues resulting from the installation of unauthorized attachments or modifications.
- Tightening of nuts, bolts, screws, etc. or adjustments.
- Natural wear or defects caused by natural wear.
- Issues due to use of improper oil, grease, or other lubricant.
- Daily allowances and overtime labor rates.
- Indirect damages such as loss of earning, etc.
- Normal maintenance services. Maintenance services not directly involved with defective parts are considered normal service and should be excluded from a claim.